

Contents

ENGLISH	2
Vehicle Details.....	2
Recommended Compressors.....	3
Parts View	4
Parts View List	5
Foreword	6
Pre-Installation	7
Installation.....	7
Mount Bracket Installation	8
Compressor Installation	10
Drive Belt.....	11
Finish	12

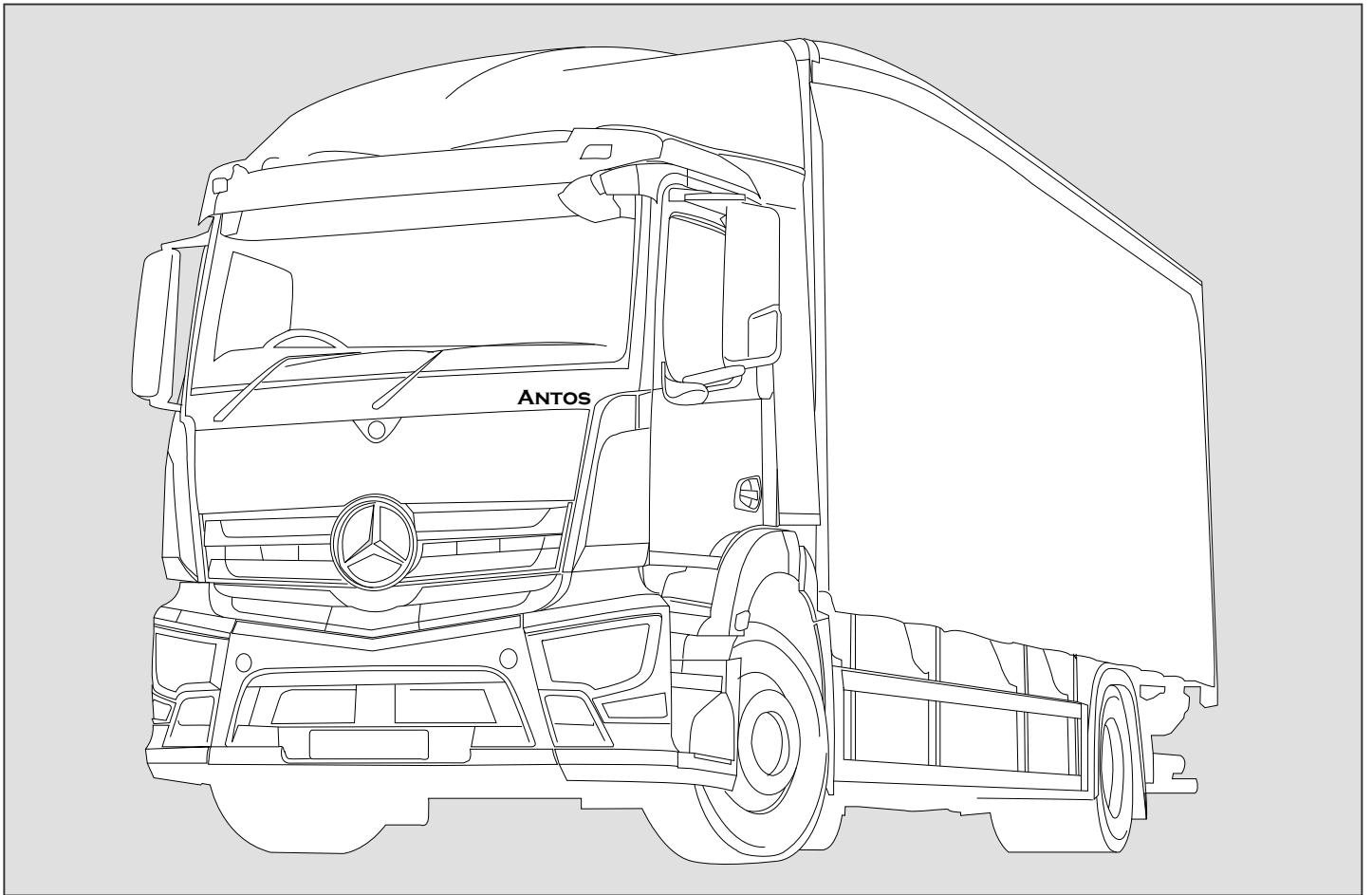

VEHICLE DETAILS

Manufacturer	Mercedes
Make	Antos Euro VI
Model	963
Engine CC	7.7 L 6 Cyl / OM936 E6
Engine Details	175/200/220/235/260 kW 238/272/299/320/354 hp
Year	2013>
Chassis Nos.	N/A
LHD	YES
RHD	YES
PAS	YES
A/C	YES / NO
Voltage	24v

KIT DETAILS

Kit Part Number	0500.7592
Description	Speed Reduction Kit Compressor RPM 3075 @ Max engine power output
Fitting Time	90 Minutes
Suction Fitting	90°
Discharge Fitting	90°
Belt Type	6PK 1215
Belt Part Number	0820.6111

RECOMMENDED COMPRESSORS

SELTEC	-	-	TM21-HS
Comp No.	-	-	0381.0632
Seltec No.	-	-	488-47246
Mounting	-	-	Direct
Rotor	-	-	8PV
GL	-	-	51.16 mm
Armature	-	-	3E
Diameter	-	-	141
Voltage	-	-	24
Orientation	-	-	-
Fitting	-	-	Pad
Manifold	-	-	Bolt

SANDEN	-	-	-
Comp No.	-	-	-
Sanden No.	-	-	-
Mounting	-	-	-
Rotor	-	-	-
GL	-	-	-
Armature	-	-	-
Diameter	-	-	-
Voltage	-	-	-
Orientation	-	-	-
Fitting	-	-	-

QUE	-	-	QP21-HS
Comp No.	-	-	0391.0632
Que No.	-	-	QP21-1563
Mounting	-	-	Direct
Rotor	-	-	8PV
GL	-	-	51.16 mm
Armature	-	-	3E
Diameter	-	-	141
Voltage	-	-	24
Orientation	-	-	-
Fitting	-	-	Pad
Manifold	-	-	Bolt

Notes

COMPRESSOR KIT CONFIGURATIONS

PART NUMBER	COMPRESSOR KIT PART NOS		DESCRIPTION	QTY.
	0521.7592	0591.7592		
0381.0632	●		TM21 Direct Mount 8PV 3E 141 24V V Pad Bolt	1
0391.0632		●	QP21 Direct Mount 8PV 3E 141 24V V Pad Bolt	1

● = Additional parts to standard kits.

PARTS VIEW

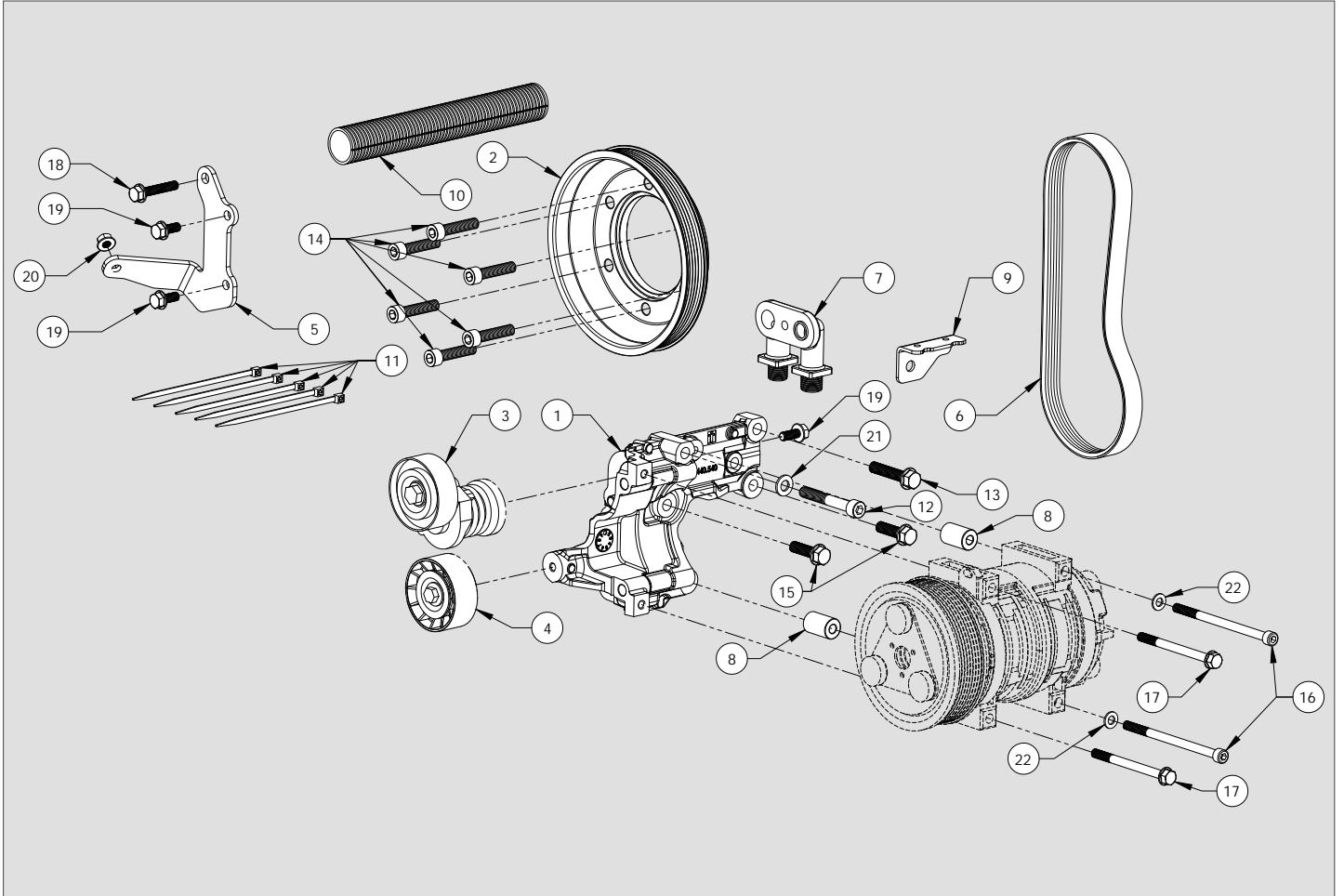

PARTS VIEW LIST

ITEM		DESCRIPTION	QTY.	COMMENTS
1	0441.5401	Compressor Mount Bracket Assembly	1	
2	1701.5311	Crankshaft Pulley	1	
3	1705.5031	Automatic Tensioner	1	
4	1700.0331	Idle Pulley Assembly	1	
5	3020.6151	Support Plate - Antos	1	
6	0820.6111	Belt - Poly Groove 6PK 1215	1	
7	0425.0251	Manifold Inverted - 3/4 x 7/8 Insert O-Ring	1	
8	2803.5741	Spacer OD 20 x ID 8.5 L31	2	
9	3020.6161	Oil Pipe Support Bracket - Antos	1	
10	1430.1012	Nylon Split Tube	1	
11	2763.0051	Cable Tie 4.8 x 370 - Black	5	
12	2705.5111	Hexagonal socket head cap screw M10 x 70 : 1.5- 12.9	1	
13	2705.0341	Hex flange bolt Durlok - M10 x 50 : 1.50 - 12.9	1	
14	2705.5271	Hex socket head cap screw M10 x 45 : 1.50 - 10.9	6	
15	2705.0241	Hex flange bolt Durlok - M10 x 35 : 1.50 - 12.9	2	
16	2704.5421	Hex socket head cap screw M8 x 130 : 1.25 - 12.9	2	
17	2704.5361	Hex flange bolt - M8 x 100 : 1.25 - 8.8	2	
18	2704.0161	Hex flange bolt Durlok - M8 x 45 : 1.25 - 12.9	1	
19	2704.0511	Hex flange bolt - M8 x 20 : 1.25 - 10.9	3	
20	2734.0021	Durlok Hexagon Flange Nut - M8 : 1.25	1	
21	2809.0011	Washer M10 Flat DIN 125 - A 10.5	1	
22	2808.0011	Washer M8 Flat DIN 125 - A 8.4	2	

FOREWORD

- The purpose of this manual is to facilitate the installation of a direct drive compressor. The information given is merely instructive, should any complications arise contact the Technical department. The manufacturer's warranty does not cover any problems caused by defective installation or alterations made unless authorised. The manufacturer shall not be responsible for any injury, damage or loss caused directly or indirectly as a result of using this manual or the information contained within it.

1 SAFETY MEASURES:

Before fitting the Compressor adapter drive kit, ensure the following for damage:

- Inner and outer trim and body work
- Engine idle pace
- Check all the vehicle functions

1.4 Check list:

- Ensure that the right kit has been selected
- Before installing, check that all the correct pieces are present; also ensure that there are no missing or broken pieces
- When fitting, make sure the vehicle is

properly protected against damage.

1.4 Installation apparatus

- Calibrated torque wrench
- Hand service tools
- Protective covers and shields

2 PRECAUTIONS

- Detach the battery negative lead.
- Torque all bolts where stated using a calibrated torque wrench.
- Take extreme care with moving parts.
- Remove the vehicles ignition key and keep it with you.
- Wear safeguards to make sure that liquid refrigerant never touches your skin

Caution: Measures must be followed accurately to steer clear of the possibility of damage to individuals

Warning: This calls awareness to actions which must be pursued to avoid damage to the components.

NB: This calls awareness to make the job easier or gives useful information.

STANDARD FASTENER TORQUE VALUES

- In the absence of specific torque values detailed in this fitting instruction manual, the following chart can be used as a guide to the maximum safe torque for specific size and grade of fastener.

STRENGTH								
	Max Torque		Max Torque		Max Torque		Max Torque	
Dia / Pitch	lb.ft	Nm	lb.ft	Nm	lb.ft	Nm	lb.ft	Nm
M5 x 0.80	2	3	4.5	6	6.5	9	7.5	10
M6 x 1.00	4	5.5	7.5	10	11	15	13	18
M8 x 1.25	10	13	18	25	26	35	33	45
M10 x 1.25	20	27	39	53	57	78	66	90
M10 x 1.50	18	25	37	50	55	73	63	86
M12 x 1.75	33	45	63	85	97	130	111	150
M14 x 2.00	55	75	103	140	151	205	177	240
M16 x 2.00	85	115	159	215	232	315	273	370

PRE-INSTALLATION

Note: Before proceeding please read the installation precautions. The letters on drawings relate to text, numbers circled relate to the parts list in this manual.

INSTALLATION

1. Disconnect the Battery
2. Remove the engine under tray (A) and side panel (B) - Fig 1
3. Disconnect the fan plug (C), Remove and retain p-clip (D) - Fig 2
4. Remove wiring plug (E) from bracket (F)
5. Remove and discard p-clip (G)
6. Remove and discard bracket (F) and 2x securing bolts - Fig 3
7. Disconnect the oil fill pipe (X) from the oil sump
8. Remove and retain the 6x securing bolts (H) securing the fan to the fan hub (J) - Fig 4
9. Remove and discard the 6x securing nuts (K) securing the fan hub (J) to the fan spacer (L) - Fig 4

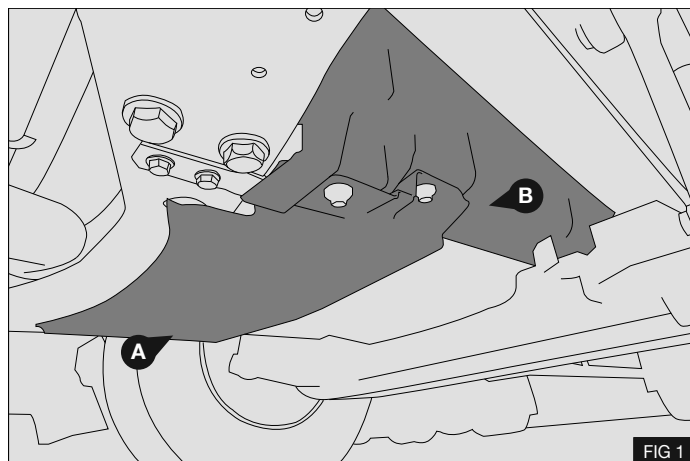

FIG 1

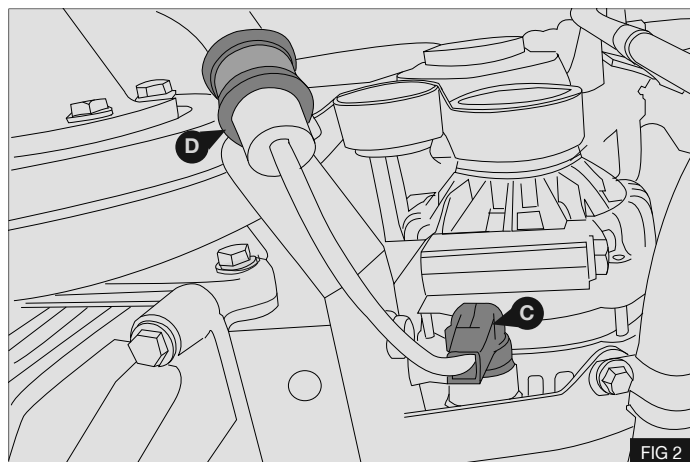

FIG 2

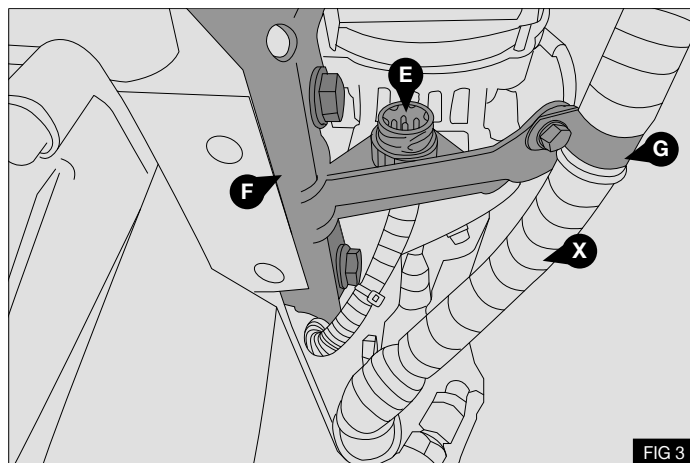

FIG 3

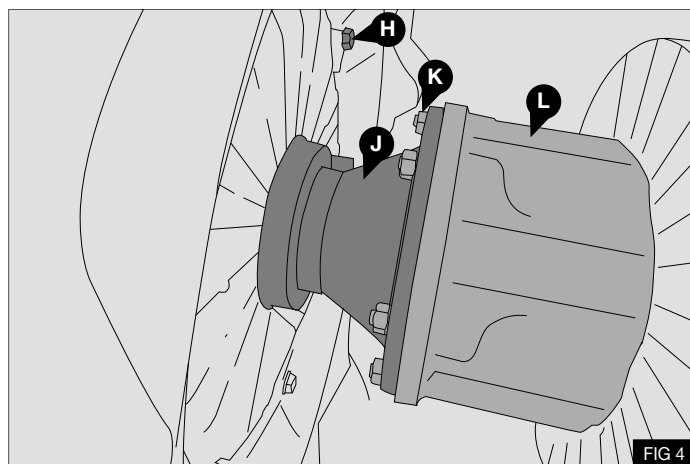



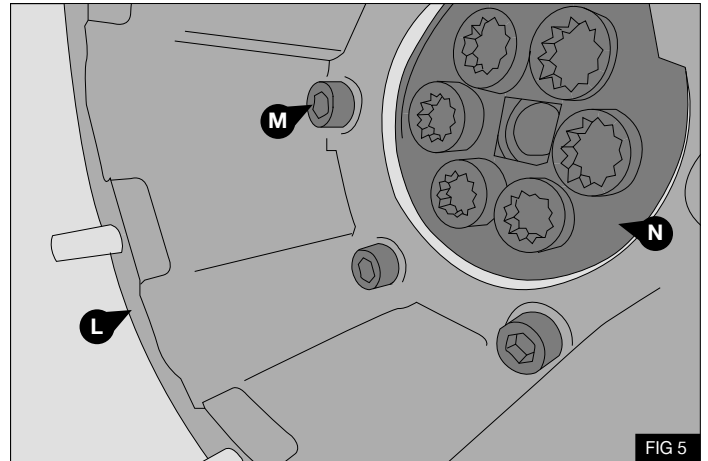



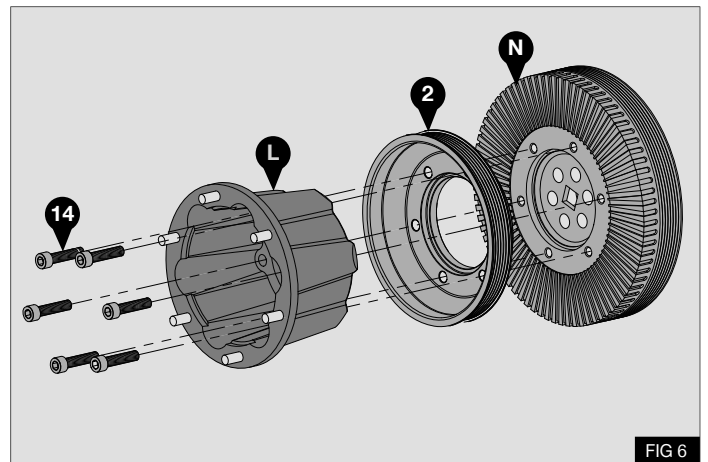



FIG 4



10. Remove and discard the 6x securing bolts  securing the fan spacer  to the crankshaft pulley  - Fig 5





11. Secure the fan spacer  and the supplied pulley  to the original crank pulley  using the supplied bolts  as shown opposite - Fig 6



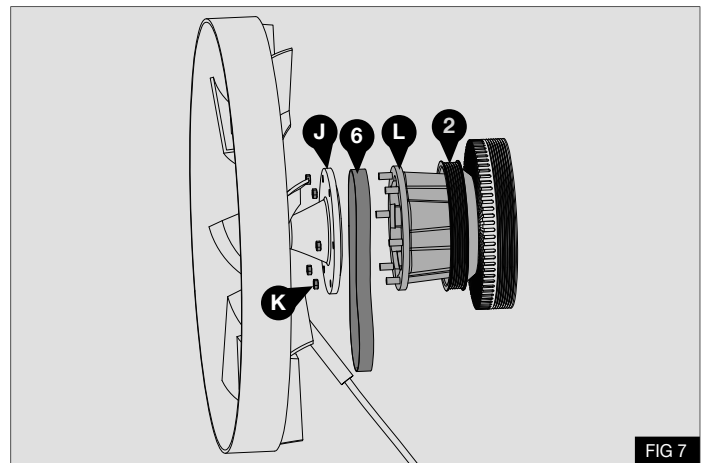

12. Torque bolts  to 50Nm / 36.8lb ft - Fig 6

13. Place the supplied belt  over the crank pulley  - Fig 7



14. Refit the 6x securing nuts  securing the fan to the fan hub  - Fig 7

15. Re-connect the fan plug  - Fig 7

16. Remove and discard M8 bolt  from the timing case - Fig 8

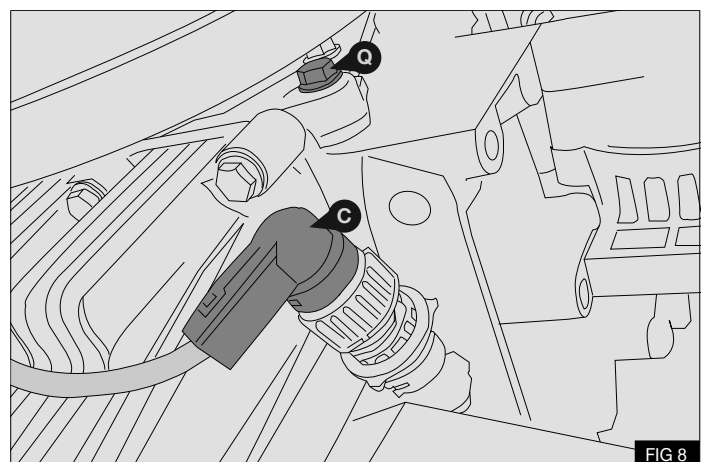

MOUNT BRACKET INSTALLATION

1. Position the automatic tensioner (3) onto the mount bracket (1) as shown opposite and secure with M8x20 bolt (19). Note position of locating dowel (R) - Fig 9
2. Torque bolt (19) to 29Nm / 21.4lb ft - Fig 9
3. Fit the mount bracket (1) to the position below the alternator. Locate the bracket to the dowel holes on the block. Secure using bolts (13), (15) and bolt (12) with washer (21) - Fig 10
4. Torque bolts (12), (13) and (15) to 58Nm / 42.8lb ft - Fig 10
5. Secure the support plate (5) to the mount bracket (1) using 2x bolts (19). Insert bolt (18) through the support plate (5) into the timing case - Fig 11
6. Torque bolts (18) and (19) to 29Nm / 21.4lb ft. - Fig 11
7. Secure the fan plug (C) to the rear of the support plate (5) using a supplied cable tie (11) - Fig 11
8. Refit the original P-clip (B) of the fan loom to support plate (5) using the original fastener into supplied nut (20) - Fig 12

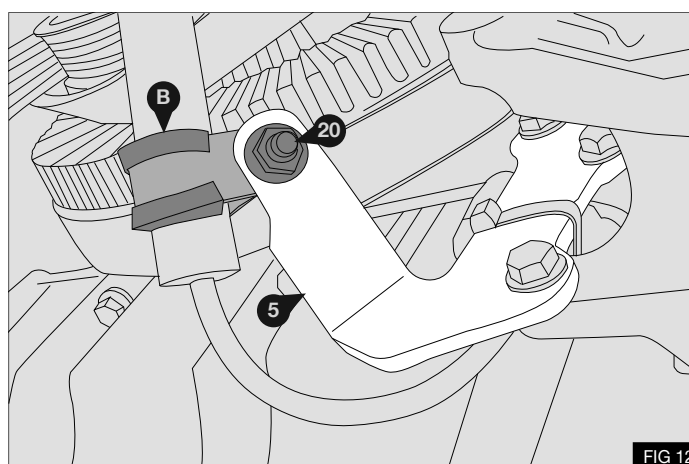
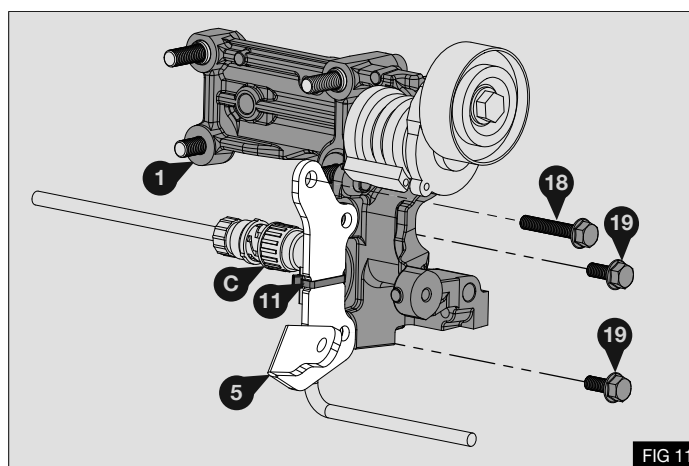
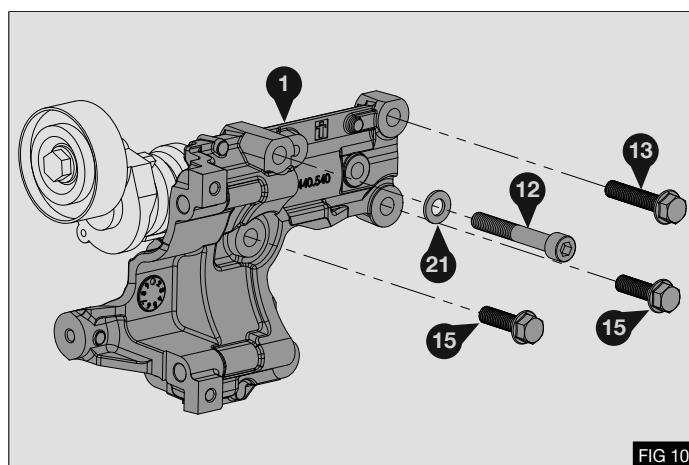
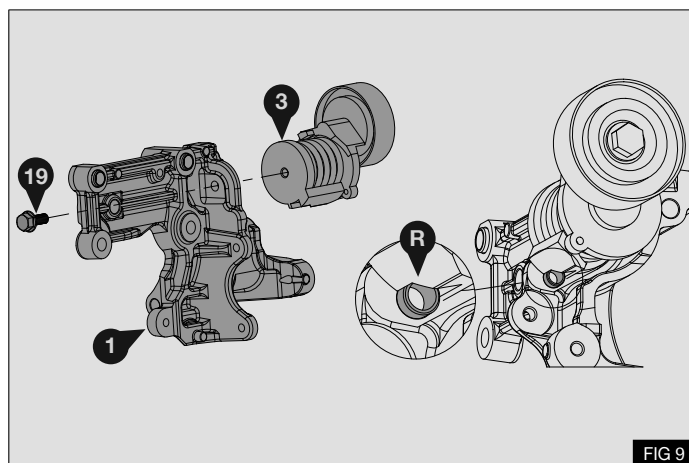

COMPRESSOR INSTALLATION

1. Install the supplied compressor manifold (7)
To the compressor in the inverted orientation as shown - Fig 13

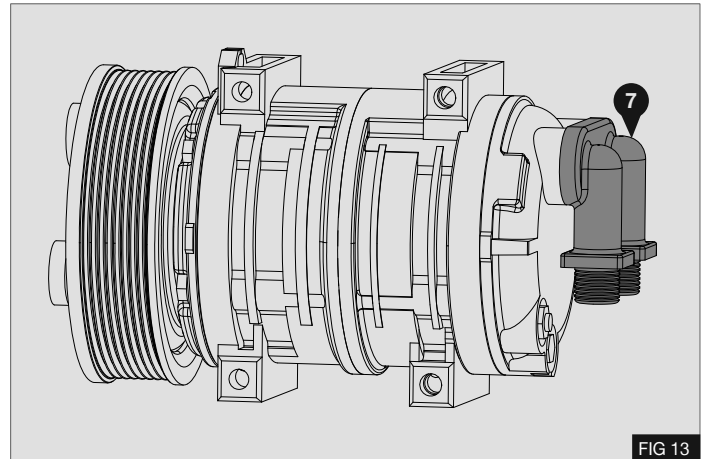

2. Install the compressor to the mount bracket (1) as shown opposite using bolts (18) at the front of the compressor. Secure the rear of the compressor using bolts (17) with washers (23) and spacers (8) - Fig 14

Torque bolts (18) to 17Nm / 12.5lb ft.

Torque bolts (17) to 29Nm / 21.4lb ft.

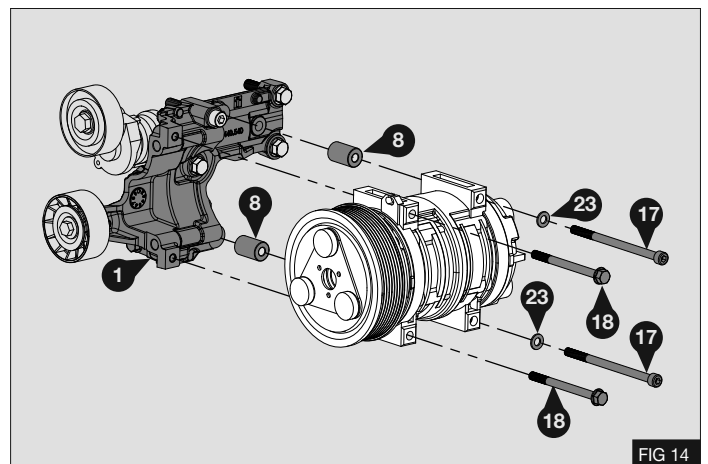

3. Install the idle pulley (4) to the mount bracket (1) - Fig 15

Torque the idle pulley retaining bolt to 25Nm / 18.4lb ft - Fig 15

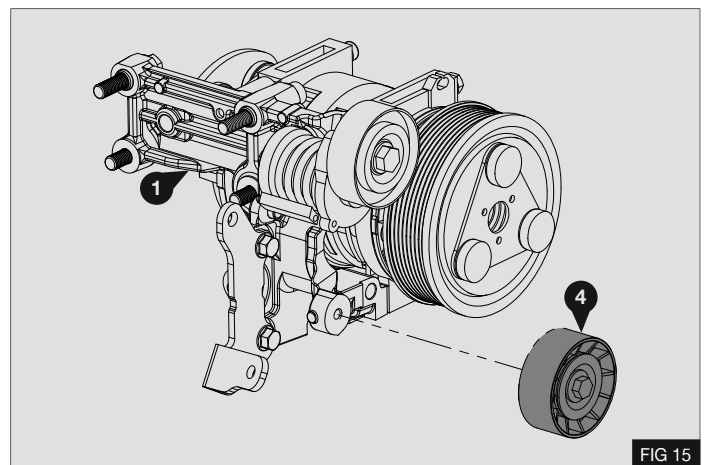

DRIVE BELT

1. Install the supplied drive belt (6) as shown opposite - Fig 16

- A – Crankshaft Pulley
- B – Tensioner Pulley
- C – Compressor
- D – Idle Pulley

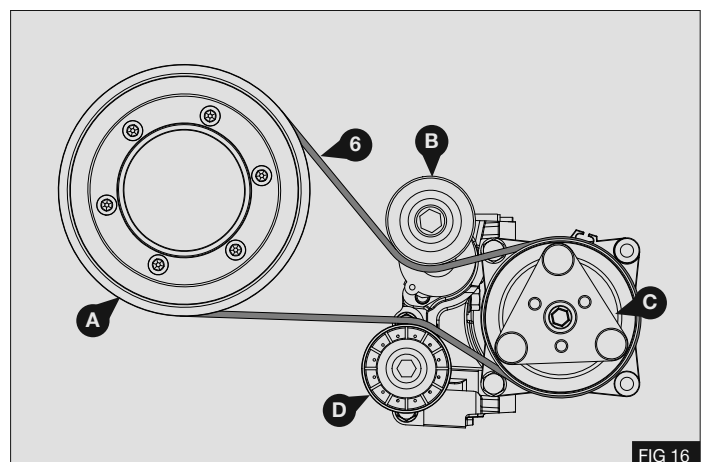

- Place the belt in the correct groove of the compressor clutch as shown opposite (Seltec / Que PV8) - Fig 17

CAUTION: Once the belt has been installed check for adequate clearance to the fan loom. If required adjust the P-clip securing the fan loom to gain maximum clearance.

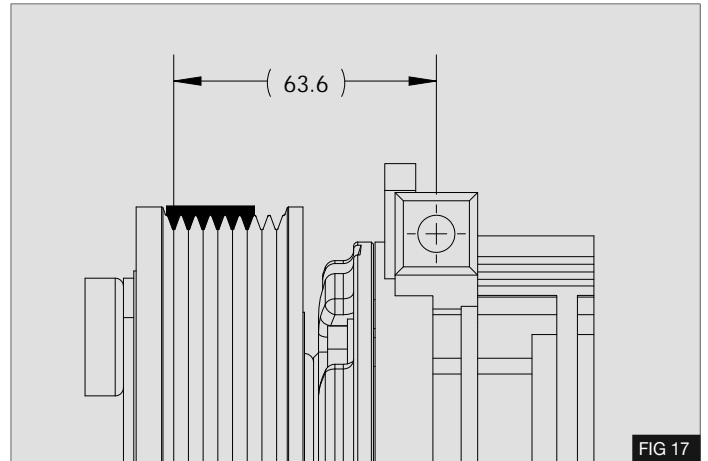

FIG 17

- Fit the supplied pipe support bracket (9) to the alternator using the original bolt (S) - Fig 18

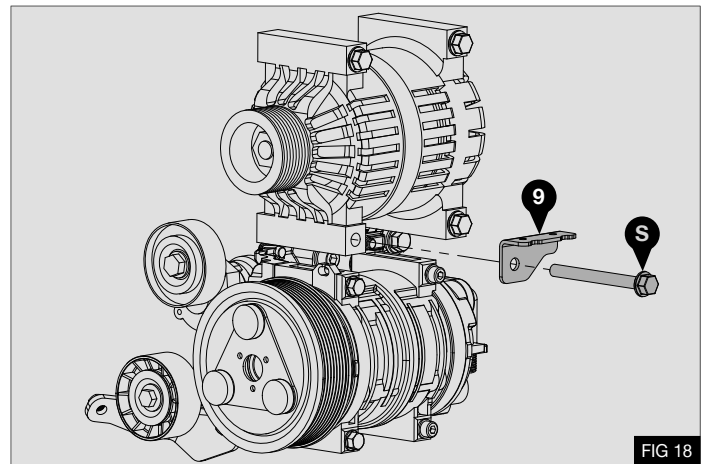

FIG 18

- Fit the supplied length of nylon split tubing (8) to the oil fill pipe (X) and re-connect to the sump.
- Secure the oil fill pipe (X) to the pipe support bracket (7) using 2x cable ties (9) - Fig 19

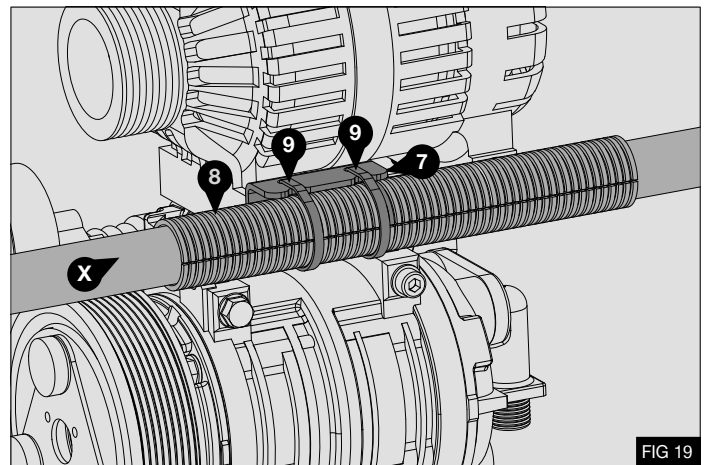

FIG 19

FINISH

- Run the engine with the compressor clutch engaged for five minutes. Check all components.
- Install the supplied belt label in the engine bay

